

Dicing of cooked & fresh poultry

The Technology

- ✓ **TWISTER** range designed for dicing of for example 10x10 mm., stripes 7x40 mm. of cooked & fresh poultry meat.
- ✓ Multifunctional cutting system to change size in a minute.
- ✓ Automatic belt loading of products into hopper for a continuous proces.
- ✓ Variable cutting speed for optimal product quality.
- ✓ Outfeed by conveyor or 200 ltr. trolley's.

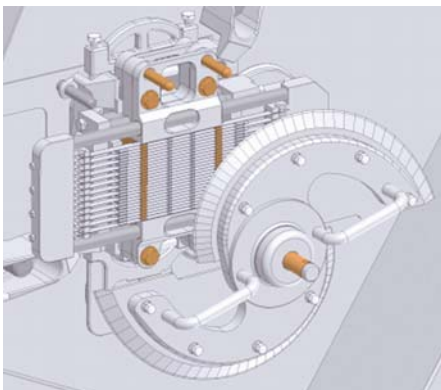

The Innovation

- ✓ Patented **Counter Acting Gridset** suitable for cutting at fresh temperature to reduce preparation times.
- ✓ By choice single, double or quadruple cutt-off knife for a capacity up to 1.500 kg./hour.
- ✓ Increased cutting length with special grid knives for longer stand time to minimize production costs.
- ✓ Easy and efficient changing of wear parts to maintain best quality with minimum waste for decades.

The Benefits

- ✓ Precision on six sides for unique market quality.
- ✓ Optimal endresult with less smaller particles causes better quality in and outside the package
- ✓ Productfluids remain inside the product for a higher yield.
- ✓ Less small particles to have transparent package image.
- ✓ Capacity increase without quality decrease!

