

JAGUAR: For a professional entrance into new markets



A look in the blade box shows a thin blade for a precise cut.



Cutting pork rib chops is "child's play" for the powerful JAGUAR.

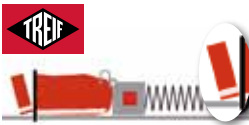

Uniform cross-section thanks to the DVS (dynamic feeding system).



Rump steak – one of the many products that can be sliced with the flexible portion cutting machine.

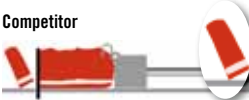

Competitor



Most user-friendly operation.



Pork belly is part of the machine's "standard repertoire".

The JAGUAR slicing and portion cutting machine is characterised by a simple design, high functionality and operational safety.



The intelligent gripper recognises which areas of the food product are harder than others (i.e. those containing bones). In this area the gripper just rests on the product. The other hooks keep a tight, secure grip on the meat.



JAGUAR can produce up to 180 cuts/min. and is available in 700 and 1,100 models. These numbers stand for the max. insertion length in mm.

The high capacity and wide variety of cutting applications make it ideal for use in the butcher's trade, canteen kitchens, industrial applications, supermarkets, and mega markets.

JAGUAR and its capabilities

It has the capability to slice bone-in products as well as boneless products. The chilled or frozen products are cut at temperatures as cold as -4 °C / 24.8 °F.

Technical data:	JAGUAR 700	JAGUAR 1,100
Max. cut-off length (mm/inch)	0,5–30; 1/50"–1 1/5"	0,5–30; 1/50"–1 1/5"
Max. cuts per minute	180	180
Cross-section of product w x h (mm/inch)	200 x 190; 8" x 7 1/2"	200 x 190; 8" x 7 1/2"
Max. infeed length (mm/inch)	700; 27 3/5"	1,100; 43 3/10"
Housing dimensions (mm/inch)		
Length/Width/Height (mm/inch)	1,910/790/1,300; 75 1/5"/31 1/10"/51 1/2"	2,580/790/1,300; 101 3/5"/31 1/10"/51 1/2"
Connecting load (kW)	2.6	2.6
Products	Up to -4 °C / 24.8 °F	Up to -4 °C / 24.8 °F
Weight (kg/lb)	204; 450	221; 487
Product specific accessoires	on request	on request

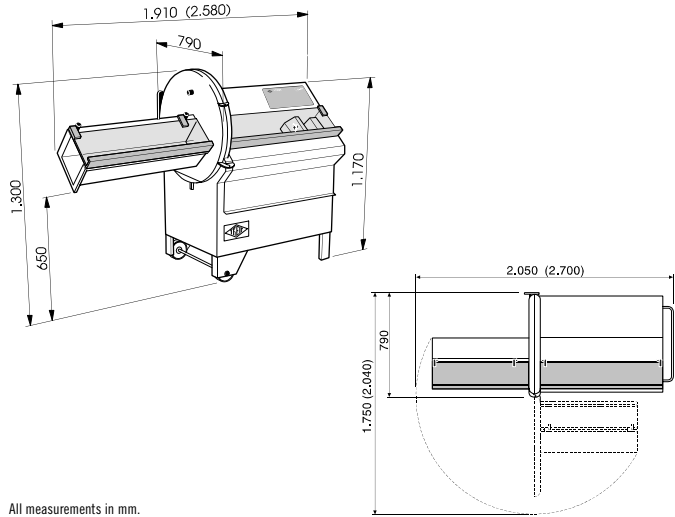

The multi-toothed gripper enables the best fixation of the boneless products (optional).



The product feed holder automatically expels the residual piece after slicing.



A sickle blade for various applications is available as an option (smooth or serrated blade).

Your benefits at a glance:

- Entrance into new markets with TREIF's smallest, yet extremely powerful cutting machine
- High-capacity portioning of boneless and bone-in products: up to 180 cuts/minute
- High-performance combined with precise portioning of products such as cutlets, steaks, schnitzel and many other products that have been chilled or frozen down to -4 °C / 24.8 °F (even deep-frozen products depending on the product and applications)
- Fulfilment of the highest hygiene requirements as a result of labyrinth guidance
- Precision sickle blade
- Intelligent product feed holder

www.treif.com

HEADQUARTERS:

TREIF Maschinenbau GmbH
Südstraße 4
D-57641 Oberlahr
Tel. +49 2685 944 0
Fax +49 2685 1025
E-Mail: info@treif.com

LOCATIONS:

TREIF S.A.R.L.
22, rue des Tuileries
F-67460 Souffelweyersheim
Tel. +33 3 8818 4018
Fax +33 3 8818 4019
E-Mail: info-france@treif.com

TREIF USA Inc.
50 Waterview Drive, Suite 130
USA-Shelton CT 06484
Tel. +1 203 929 9930
Fax +1 203 929 9949
E-Mail: treifusa@treif.com

TREIF U.K. Ltd.
4 Europa Park
Croft Way Eastways
GB-Witham Essex CM 8 2FN
Tel. +44 1376 504060
Fax +44 1376 504070
E-Mail: info@treif.co.uk

TREIF in Belgium
Villalaan 21
B-9320 Aalst
Tel. +32 53 770813
Fax + 32 53 789666
E-Mail: jo.luybaert@treif.com

TREIF China
TREIF Maschinenbau GmbH
Room 212, No. 188 Zhangyang Rd.
PRC-Shanghai, 200120 China
Tel. +86 21 5879 8255
Fax +86 21 5879 8256
E-Mail: treif.china@treif.com